

RB-VULCANO BASE



ROBOTIC MOBILE
PLATFFORM
FOR INDUSTRIAL
APPLICATIONS

LOGISTICS, WAREHOUSES
& OTHERS

INTRA-LOGISTICS
APPLICATIONS

APPLICATIONS IN
HARSH ENVIRONMENTS

OPTIONS

DOCKING STATION

LIFTING UNIT

DIGITAL & ANALOG

I / O MODULE

MAGNETIC GUIDANCE SENSORS

ROLLER PLATFORM



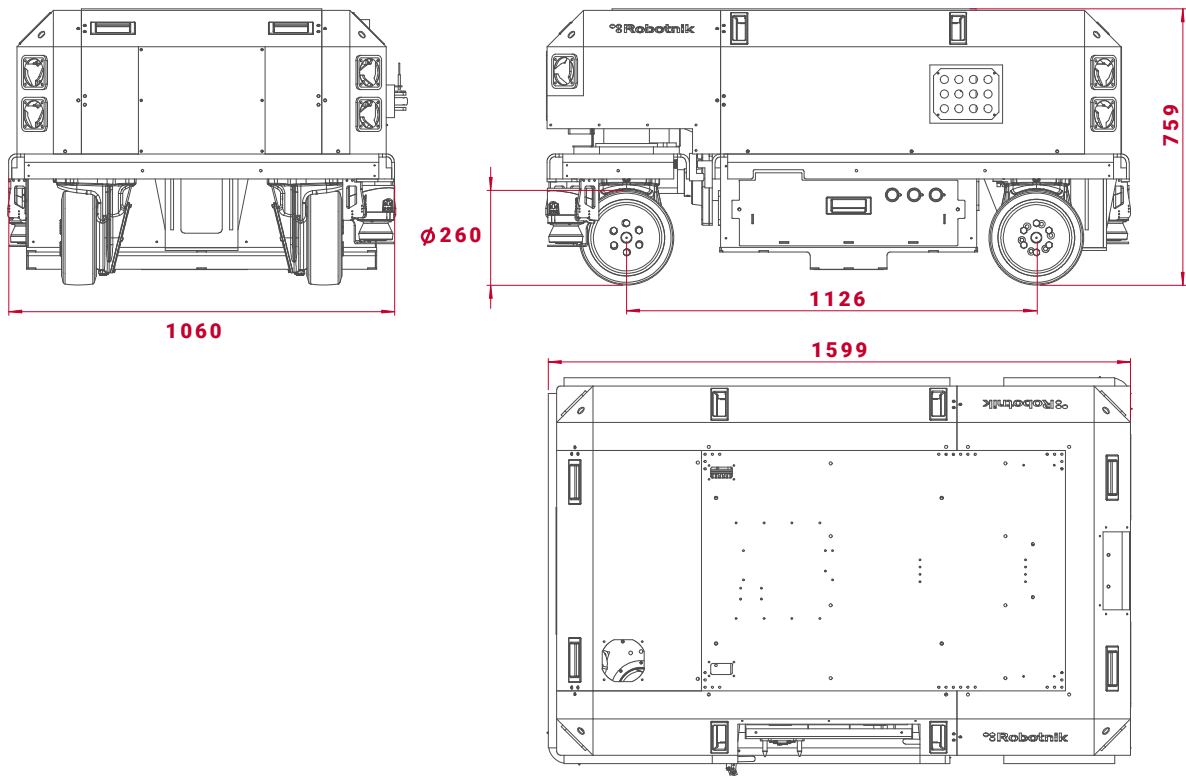

TECHNICAL SPECIFICATIONS

MECHANICAL

Dimensions **1.599 x 1.060 x 759 mm**

Weight **750 kg**

Payload **1750 kg**

Speed **1 m/s**

Enclosure class **IP21**

Traction system **Single Ackermann | Dual Ackermann | Omni-drive (swerve drive)**

Traction motors **4 x 1200 W**

Direction motors **4 x 500 W**

Batteries **LiFePO₄ 200Ah@48V**

Temperature range **0° to +45°C**

CONTROL

Controller **Open architecture ROS Embedded PC with Linux**

Communication **WiFi 802.11n**

Connectivity **On demand**